

»BISON« D 1500 TECHNICAL DATA



UNDER REALISTIC CONDITIONS AT THE AIRPORT:

With an aircraft tow tractor including 4-wheel-drive and equal weight distribution on both axles, on wet concrete (friction coefficient $\mu=0.57$), 1% apron inclination, and aircraft engines running during pushback.

In case of different requirements please contact us for new calculations based on your specific operation conditions.

OPERATION WEIGHTS	+ 50 t 52 t 55 t 60 t 65 t 70 t max.
MTOW	+ 600 t
DRAWBAR PULL INSTALLED	+ 460 kN ^[1]

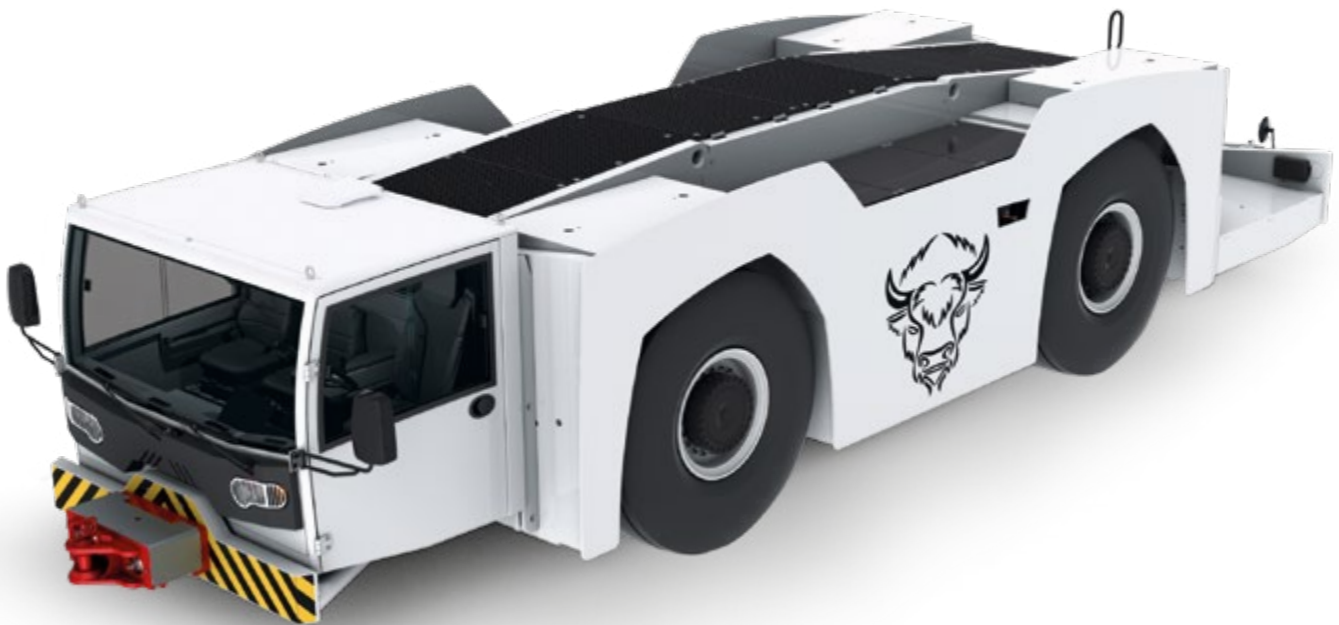

FIND OUT MORE
»BISON« FAMILY

^[1] Depending on tyre variation

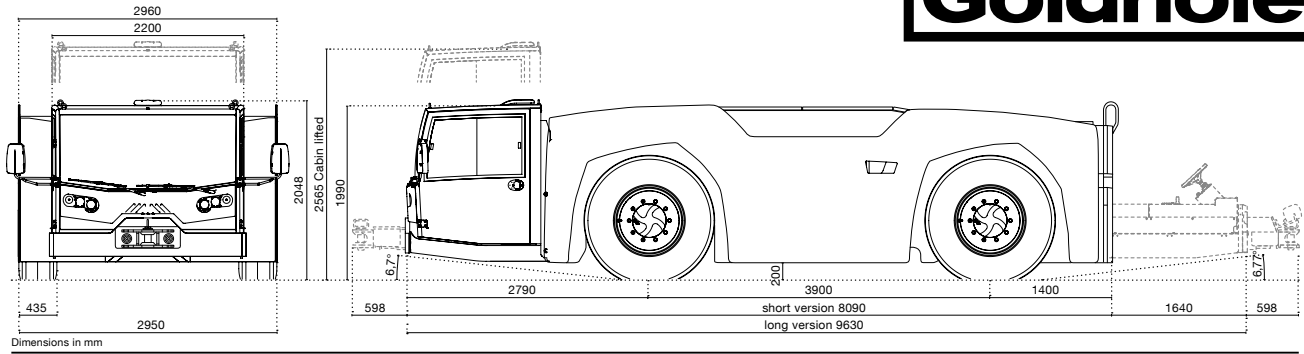

Dimensions in mm



ENGINE

- + CUMMINS X12, 298 kW
- + DEUTZ 215V6, 300 kW
- + Fuel tank capacity max. 200 l
- + EU STAGE V
- + EU STAGE IIIA
- + US EPA TIER 4F



TURNING RADIUS

- + 7,140 mm
- + * 7,500 mm long version

TRANSMISSION

- + 6 gears forward/3 reverse
- + Draw bar pull limiter dependent on selected aircraft type
- + ZF automatic full-power-shift transmission with integrated torque converter, manual and automatic gear-shifting mode

AXLES

- + Driven steering axles with planetary drives in the wheel hubs
- + Front and rear axles driven by full-power-shift transmission through joint shafts

STEERING SYSTEM

- + Standard 4-wheel steering
- + Front-wheel and crab steering (optional)
- + Emergency steering pump

TIRES

- + 16.00x25
- + 18.00x25

BRAKES

- + 2-circuit service brake
- + 1-circuit failsafe parking brake
- + Brake pad wear indicator
- + Emergency parking-brake release by electrical emergency pump

HYDRAULIC SYSTEM

- + Brakes and steering system
- + Cabin-lift and jacks

ELECTRIC SYSTEM

- + Alternator 28 V/110 A
- + Battery capacity 2x12 V/225 Ah
- + Engine starter 7.5 kW

CABIN

- CABLESS + Full-width elevating, all-steel front cabin
- BASIC CABIN + Comfortable driver's and passenger's seat with safety belts (third seat optional)
- + Adjustable steering column
- + Interior lights
- OPEN CAB + Wiper-washer system for front
- OPTION + Rear-view mirrors (1 inside, 2 outside)
- + Front tow-hitch mirror
- CLOSED CAB + Lockable doors with sliding windows
- OPTION + Cabin/windscreen ventilation and heating
- + Heated rear window with screen wiper



OPTIONS EXAMPLES

- + Cushioned tow hitch
- + Aircondition system
- + Second passenger seat
- + Electrically adjustable and heated rearview mirror
- + Rear-view camera
- + Auxiliary heater Webasto with timer
- + Central lubrication system
- + Remote Control
- + 4 integrated hydraulic jacks

GOLDHOFER AKTIENGESELLSCHAFT

Donaustrasse 95, 87700 Memmingen/Germany
Web: www.goldhofer.com, E-Mail: info@goldhofer.com

SALES

Telephone: +49 8331 15-343,
E-Mail: sales-airporttechnology@goldhofer.com

SERVICE AND SPARE PARTS

Telephone: +49 8331 962 99 99, Fax: +49 8331 15-247
E-Mail: service-airporttechnology@goldhofer.com

MADE FOR YOUR MISSION