



# Goldhofer



## SPECIAL SALE

### Semitrailer STN-L 3 - 39/80 F2 „Bau“

**As long as available on stock!**



+49(0)8331-15341  
semitrailer@goldhofer.de



## Equipment

- Air suspension incl. lifting/lowering +140 / -60 mm
- SAE-Gigant axles
- EBS-electronic brake system
- Douglasie wood flooring
- 4 pairs of stake pockets 100x50 mm
- 5 pairs of lashing rings (RBS 5) in the outer frame
- 5 pairs of lashing rings (APS 5) in the goose neck and loading platform
- Excavator recess (L x W x H) 3.550 x 674 x 340/240 mm in the bogie, valid for 1.600 mm rear overhang
- Pneumatic reverse steering lock device, manually operated
- 2 pairs of over width marker-boards incl. holder and socket
- Holder for over width light, incl. socket
- 1 set of aluminium side walls on the goose neck, 400 mm high
- Spare wheel carrier under the loading platform
- Frame designed for point loads
- Integrated perforated bar for removable aluminium ramps
- Prepared for the installation of side extensions
- \* one-piece ramps 2.850 x 720 mm, with mechanical ramp actuation
- Drop down legs at rear bevel

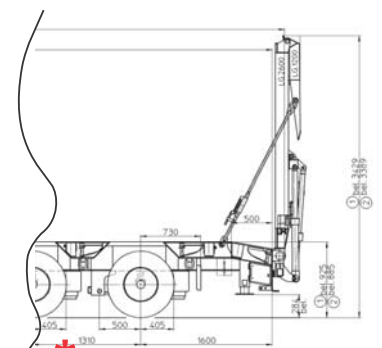
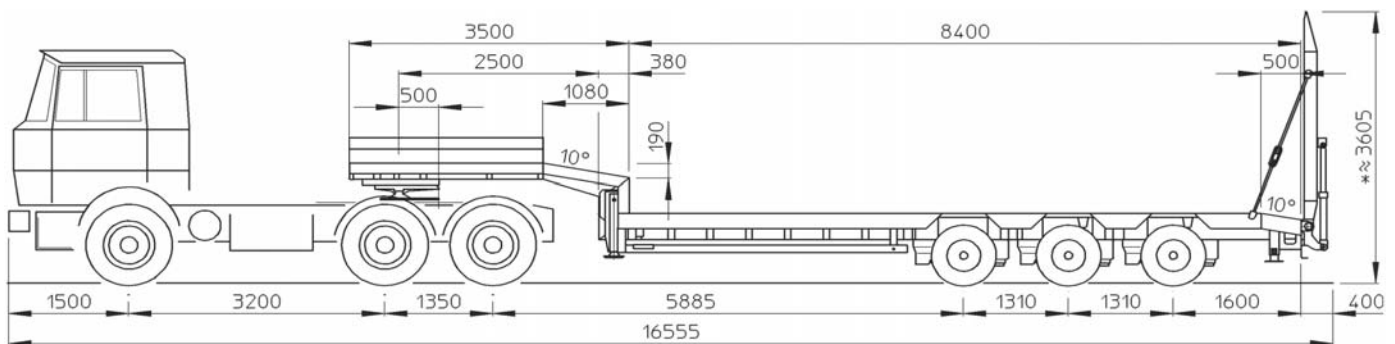

\* Two-piece ramps available

## Technical Data refer to Vehicle-No. 32557, RAL 9006 „white aluminium“

Speed		80 km/h
5th wheel load / axle load		18 000 kg / 3 x 10 000 kg
Gross weight		48 000 kg
Dead weight	approx.	10 000 kg
Payload	approx.	38 000 kg
Loading platform incl. 500 mm rear bevel		8 400 mm x 2 550 mm
Loading height in driving position, laden	approx.	885 mm +140/-60 mm
5th wheel height, laden		1 285 mm
Tyres (12-off), Pirelli		235/75 R 17,5
Swing learance radius front/ rear		1.420 mm / 2.500 mm