

## F396 TECHNICAL DATA



### UNDER REALISTIC CONDITIONS AT THE AIRPORT:

With an aircraft tow tractor including 4-wheel-drive and equal weight distribution on both axles, on wet concrete (friction coefficient  $\mu=0,57$ ), 1% apron inclination, and aircraft engines running during pushback.

In case of different requirements please contact us for new calculations based on your specific operation conditions.

VEHICLE	F396E	F396C	F396P
OPERATION WEIGHTS	+ 46-60 t max.	+ 46-70 t max.	+ 50-70 t max.
MTOW MAX.	+ 400 t	+ 600 t	+ 600 t
DRAWBAR PULL INSTALLED	+ 370 kN	+ 420 kN	+ 460 kN



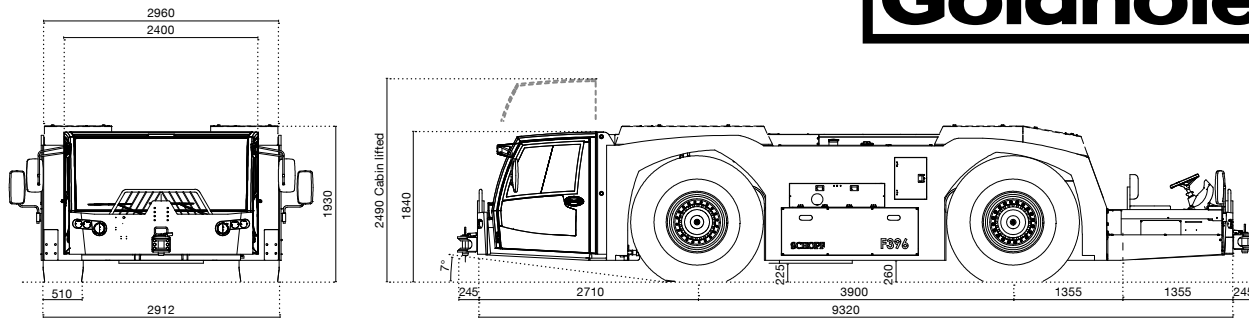

## DIESEL DEUTZ TCD

### F396E

EU Stage IIIA, IIIB  
US EPA Tier 3, 4i

2013 L06, integrated EMR  
200 kW at 2,300 rpm,  
990 Nm at 1,200 rpm

7.8 L06, integrated EMR  
200 kW at 2,200 rpm,  
1,050 Nm at 1,450 rpm

### F396C

EU Stage IIIA, IV  
US EPA Tier 3, 4f

2015 V06, integrated EMR  
300 kW at 2,100 rpm,  
2,000 Nm at 1,300 rpm

12.0 V06, integrated EMR  
300 kW at 2,100 rpm,  
2,000 Nm at 1,400 rpm

### F396P

EU Stage IIIA, IIIB  
US EPA Tier 3, 4i

2015 V06, integrated EMR  
330 kW at 2,100 rpm,  
1,990 Nm at 1,300 rpm

12.0 V06, integrated EMR  
330 kW at 2,100 rpm,  
2,000 Nm at 1,400 rpm



## TURNING RADIUS

+ 6,900 mm

## TRANSMISSION

+ 6 gears forward/3 reverse  
+ Jerk-free, automatic full-power shift with  
integrated torque converter

+ ZF ergopower  
F396E: WG210  
F396C/P: WG310

## AXLES

+ Driven steering axles with planetary  
drives in the wheel hubs

+ Front and rear axles driven by full-power-  
shift transmission through joint shafts

## STEERING SYSTEM

+ Electro-hydraulic steering  
+ Front wheel steering  
+ Rear wheel steering

+ 4 wheel steering, coordinated  
+ Crab steering

## TIRES

+ Front + rear 16.00/18.00x25

## BRAKES

+ Fully hydraulic 3-circuit safety disk-brake  
system with accumulator back-up  
+ 2-circuit service brake

+ 1-circuit failsafe parking/emergency brake  
+ Electrically driven emergency pump

## HYDRAULIC SYSTEM

+ Brakes and steering system

+ Cabin-lift and jacks

## ELECTRIC SYSTEM

+ Alternator 28 V/80 A  
+ System 24 V  
+ Engine starter  
F396E: 4.0 kW  
F396C/P: 6.5 kW

+ Battery capacity  
F396E: 2x12 V/143 Ah  
F396C/P: 2x12 V/200 Ah

## CABIN

+ Full-width elevating, all-steel front cabin  
+ 2 headlights, low and high beam  
+ Lockable doors with sliding windows

+ Two adjustable suspension seats with  
safety belts



## OPTION EXAMPLES

+ Hydropneumatic suspension  
+ Rear driver's stand  
+ Rear driver's cabin  
+ GPU platform  
+ Various tow hitches  
+ Winterization-kits

+ Heating system  
+ Airconditioning  
+ Cabin-roof light barrier or antenna sensor  
+ 4 integrated hydraulic jacks  
+ Rear-view video camera

## GOLDHOFER AIRPORT TECHNOLOGY

Location: Donaustrasse 95, 87700 Memmingen/Germany  
Location: Parkstrasse 19-21, 73760 Ostfildern/Germany  
Web: www.goldhofer.com, E-Mail: info@goldhofer.com

## SALES

Telephone: +49 8331 15-343,  
E-Mail: sales-airporttechnology@goldhofer.com

## SERVICE AND SPARE PARTS

Telephone: +49 8331 962 99 99, Fax: +49 8331 15-247  
E-Mail: service-airporttechnology@goldhofer.com

**MADE FOR YOUR MISSION**