

F59 TECHNICAL DATA



UNDER REALISTIC CONDITIONS AT THE AIRPORT:

With an aircraft tow tractor including 4-wheel-drive and equal weight distribution on both axles, on wet concrete (friction coefficient $\mu=0,57$), 1% apron inclination, and aircraft engines running during pushback.

In case of different requirements please contact us for new calculations based on your specific operation conditions.

OPERATION WEIGHTS	+ 5 t 6,2t 7 t max.
MTOW MAX.	+ 70t
DRAWBAR PULL INSTALLED	+ 45 kN 48 kN



FIND OUT MORE
F59

MADE FOR YOUR MISSION

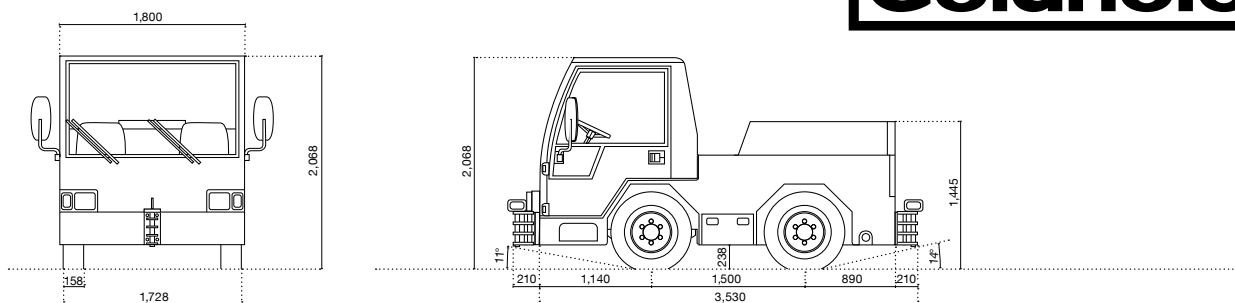

ENGINES

PERKINS 1104D-44T
EU Stage IIIA
US EPA Tier 3

- + Water-cooled
- + Turbo-charged, 4-cylinders
- + 57.5 kW at 2,200 rpm
- + 302 Nm at 1,400 rpm

DEUTZ TD 2011 L04
EU Stage IIIA
US EPA Tier 3

- + Air/oil-cooled
- + Turbo-charged, 4-cylinders
- + 54.7 kW at 2,600 rpm
- + 230 Nm at 1,700 rpm

DEUTZ TCD 2.9 L04
EU Stage V
US EPA Tier 4

- + Water-cooled
- + Turbo-charged, 4-cylinders
- + 55.4 kW at 2,600 rpm
- + 375 Nm at 1,400 rpm



TURNING RADIUS

- + 4,360 mm

TRANSMISSION

- + 2 forward/2 reverse gears
- + Inter-axle differential
- + Graziano PST 2, full-power-shift transmission
- + Integrated torque converter, electro-hydraulic gear shifting

AXLES

- + Front steering axle spring-suspended
- + Rear axle rigidly mounted
- + 4-wheel drive

STEERING SYSTEM

- + Hydraulic Orbitrol steering
- + Front wheel steering
- + Left hand drive

TIRES

- + Front + rear 8.5 R17.5

BRAKES

- + Fully hydraulic, maintenance free, enclosed oil-immersed lamella disk brakes on front and rear axle
- + 2-circuit service brake
- + 1-circuit failsafe parking/emergency brake on rear axle
- + Emergency hand pump

HYDRAULIC SYSTEM

- + Brakes and steering system

ELECTRIC SYSTEM

- + System 24 V
- + Alternator 28 V/55 A
- + Battery capacity 2x12 V/88 Ah
- + Engine starter 3.5 kW

CABIN

- + Full-width, all-steel elevating front cabin
- + Two adjustable suspension seats with safety belts
- + Adjustable steering column
- + 2 headlights, low and high beam



OPTIONS EXAMPLES

- + Elevating cabin
- + Cabin-roof light barrier or antenna sensor
- + Various tow hitches
- + Engine monitoring system
- + Winterization kits
- + Cold-start kits
- + Heating systems
- + Right hand drive

GOLDHOFER AIRPORT TECHNOLOGY

Location: Donaustrasse 95, 87700 Memmingen/Germany
Location: Parkstrasse 19-21, 73760 Ostfildern/Germany
Web: www.goldhofer.com, E-Mail: info@goldhofer.com

SALES

Telephone: +49 8331 15-343,
E-Mail: sales-airporttechnology@goldhofer.com

SERVICE AND SPARE PARTS

Telephone: +49 8331 962 99 99, Fax: +49 8331 15-247
E-Mail: service-airporttechnology@goldhofer.com

MADE FOR YOUR MISSION